

Combined Optimal Design and Control With Application to an Electric DC Motor

Julie A. Reyer

Research Fellow
email: reyer@umich.edu

Panos Y. Papalambros

Professor
email: pyp@umich.edu

Optimal Design Laboratory
Department of Mechanical Engineering
University of Michigan
Ann Arbor, MI 48109

In the design and optimization of artifacts requiring both mechanical and control design, the process is typically divided and performed in separate steps. The physical structure is designed first, a control strategy is selected, and the actual controller is then designed. This article examines how this separation could affect the overall system design and how the combination of the separate problems into a single decision model could improve the overall design, using an electric DC motor as a case study. The combination is challenging since the two problems often have different design criteria, decision objectives, and mathematical model properties. Furthermore, the two problems are often fully coupled in that the physical structure depends on the controller and the controller depends on the physical structure. A Pareto analysis is suggested as a rigorous way to compare a variety of design scenarios. [DOI: 10.1115/1.1460904]

Keywords: Combined Design and Control, Optimization, Electric DC Motor

1 Introduction

Modern mechanical artifacts are increasingly “smart.” Artifacts are designed to function in a changing environment and to adapt to these environment changes. In creating such artifacts we first tend to “create the design” (its topology and embodiment) and then “design the control” (affect its response). These design tasks are generally treated as partially coupled— with the design affecting the control, but not the control affecting the design— encouraging a sequential approach to performing the tasks. Since the initial design of the artifact affects its control characteristics, control-related design criteria must be incorporated early in the design process, when adaptive performance is important and/or expensive.

One way to account for the coupling effects is to introduce an iteration. An initial design is optimized, then its control is optimized; the performance of the design under this control is then studied and the design problem is modified if its controlled response is not satisfactory. One issue that comes up in such an approach is the order of the sequence. Should the artifact be designed first and then the control, or vice versa? Would changing the order of solution also change the solution itself?

These issues have been addressed primarily in the controls community for some time. Researchers in the areas of structures and mechatronics have brought the issue to the forefront demonstrating in several articles that design and control needs to be considered together as a single optimization problem (see, for example, [1–3]). The literature explores various methods that work under specific circumstances. In those applications the problems are partially coupled. In designing an electric motor, the case study in this article, the problem is fully coupled: in order to design the motor, power and torque ratings must be assumed, which in turn must be related to the power and torque that the controlled motor actually uses. This article adapts methods from the literature to solve the fully coupled problems, which creates several new issues. The most daunting issue is whether the strategies can achieve the same answer, and, if not, whether that is intentional or not. Theoretical questions, such as under what conditions the answers are the same, quickly follow.

The article begins to explore these questions assuming a design

or synthesis point of view. How should the design and control be combined? How can we formulate a combined optimal design and control problem? How does the solution sequence affect the solution? Using a classical example of an electric direct current (DC) motor, several techniques of optimizing the design and control system are examined in an empirical manner to explore the possibilities. The example shows that it does make a difference how one combines the tasks and paves the way for theoretical questions that must be studied further. A DC motor is typically selected with a specific application in mind. Here the “application” is specified with a load torque profile and a desired load speed. The motor weight and speed error are critical. A motor and controller must be developed to meet these needs optimally.

In the following sections a consistent design and control terminology is presented first. Fully coupled models for the motor design and control are developed. Strategies for performing the optimal design and optimal control tasks are then outlined and applied to the models. The results of these computations are presented and used to pose some broader research issues in the optimization of artifacts that require both design and control considerations.

2 Optimal Design and Control

Over the years design and control theorists have developed a standard set of symbols and terminology for each field. As focus turns toward combining design and control into a single system theory, there is an immediate need to distinguish the representation of quantities and equations used for the design and the control sides. This section seeks to formalize a common language for combined design and control problems.

For the purposes of this paper, several conventions are observed. In a function representation, such as $f(\mathbf{x};\mathbf{p})$, all quantities before the semicolon are considered variables and all quantities after the semicolon are considered parameters of the function. Parameters are fixed during the optimization process involving the function. Vector quantities appear in bold. The nomenclature used is summarized in Table 1.

2.1 Artifact Design. Artifact design in this context is the use of a mathematical model to determine appropriate values of variables in the model. The mathematical model, called a *General Design Problem* (GDP), defines the relevant relationships and restrictions of a physical system to its quantities of interest, the

Contributed by the Design Automation Committee for publication in the JOURNAL OF MECHANICAL DESIGN. Manuscript received Oct. 1999. Associate Editor: J. M. Vance.

Table 1 Nomenclature for generic optimization models

Design Problem Formulation	
<i>a</i>	simple <i>design</i> parameters
<i>b</i>	<i>design</i> parameters, based upon the control problem
<i>c</i>	parameters of the <i>design</i> problem = { <i>a</i> , <i>b</i> }
<i>d</i>	design variables
<i>f</i>	objective for the design problem
<i>h</i>	equality constraints for the design problem
<i>g</i>	inequality constraints for the design problem
<i>q</i>	number of design variables
<i>v</i>	<i>control</i> parameters, based upon the design problem
Control Problem Formulation	
<i>B</i>	<i>design</i> parameters, based upon the control problem
<i>J</i>	performance index, objective for the control problem
<i>j</i>	time dependent performance index, will generally be integrated with respect to time
<i>k</i>	equality constraints for the control problem
<i>l</i>	inequality constraints for the control problem
<i>m</i>	number of state variables
<i>n</i>	number of control variables
<i>p</i>	vector of control gains for a controller configuration
<i>r</i>	dynamical equations for the control problem
<i>s</i>	response relations for the control problem
<i>t</i>	time continuum
<i>u</i>	simple control parameters
<i>v</i>	<i>control</i> parameters, based upon the design problem
<i>w</i>	parameters of the <i>control</i> problem = { <i>u</i> , <i>v</i> }
<i>x(t)</i>	state variables as a function of time
<i>y(t)</i>	measurable response of the controlled system
<i>z(t)</i>	control variables as a function of time

design variables, *d*, and the design parameters, *c*. Design variables describe the design; assigning a set of values to the design variables gives a specific design. Design parameters describe the quantities that are considered to be fixed during a design study. For examination of the combined design and control problem, the design parameters have been separated into two types: *a*, “simple” parameters of the design problem that do not depend on the control problem, and *b*, parameters of the design problem that do depend on the control problem, so *c*={*a*,*b*}, Fig. 1. Similarly, *v* is the set of parameters of the control problem that depend on the design problem, so *v*=*V*(*d*; *c*). The vectors *g* and *h* represent inequality and equality constraint functions, respectively. The set of all possible design variables that satisfy the constraints of the GDP is called the *feasible space*.

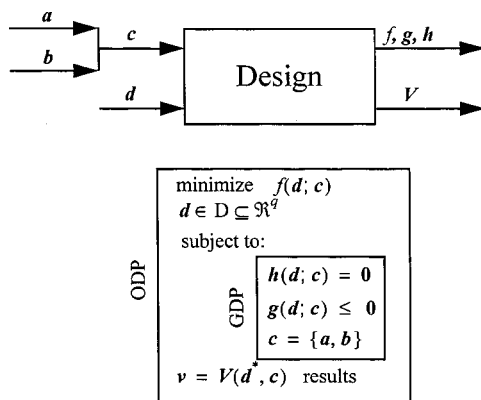

Fig. 1 Design problem

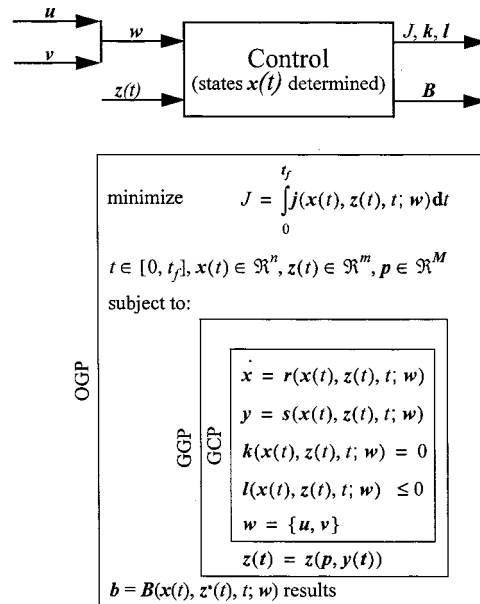

Fig. 2 Control problem

Decisions regarding the determination of the best set of design variables in the feasible space generally involve the transformation of the GDP into an Optimal Design Problem (ODP) by adding a scalar metric, the objective function *f*, Fig. 1. Many well-known methods exist to solve the ODP mathematically and find an optimum. Quantities at the optimum are indicated with a superscript asterisk. In this formulation the solution to the ODP determines the parameters *v*=*V*(*d**; *c*), as a result of the optimization. However, the optimal design *d** should be checked to confirm that it allows the existence of the coupling parameter values, namely, that a set of ‘acceptable’ control parameters exists at the optimal design solution. Checking such acceptability without carefully studying the control problem can be difficult or impossible.

2.2 Artifact Control. Artifact control attempts to achieve a desired response in a dynamic physical system. A mathematical model of the dynamic system, the *General Control Problem* (GCP), defines the relationships between inputs and outputs of a system over a time continuum and may include constraints or bounds on the system. The inputs to the system are the control signal *z(t)* and parameters *w*. As in the design problem, the control parameters are divided into two sets, *u* and *v*, which represent “simple” parameters *u* that do not depend on the design problem and parameters *v* that do depend on the design variables, Fig. 2. A resultant set of parameters *B* indicates the effect of the control problem on the design problem. The states *x(t)* of the system in time are related to the inputs by the dynamical equations *r*. The response relations *s* define how the inputs and states prescribe the measurable response *y(t)* of the system. The equalities and inequalities, *k* and *l*, respectively, represent constraints and bounds on the system. A special case of the GCP is the general gain problem (GGP). The GGP has an extra constraint, called a control strategy, that relates the control signal *z* to the response *y* and controller gains *p*. This relationship is predefined for a given problem based on an engineer’s experience and experimentation.

Similar to the design problem, the GGP is expanded into an *Optimal Gain Problem* (OGP) by adding a performance index, the functional *J*, which is minimized to find *z(t)* for a prescribed period in time, from *t*=0 to *t_f*, Fig. 2. The solution to the OGP is the optimal control function *z**(*t*). The parameters *b* can then be determined: *b*=*B*(*x(t)*, *z**(*t*), *t*; *w*).

In the present study we assume that a control strategy has al-

ready been selected (or would be selected as a separate decision task) and that the function $\mathbf{z}(t)$ is defined relative to this particular controller, as mentioned previously.

2.3 Combined Design and Control. When one wants to design and control an artifact “optimally,” the implication is that the solution should be optimal for the whole system. The concept behind the combined optimization formulation is that the solutions arising from separate design and control optimizations may not be optimal from an overall system standpoint [4,5]. For example, the effect of the embodiment of the artifact on its control can be important [6].

In some systems, such as DC motors, the embodiment of the artifact affects its control and the control of the artifact affects its embodiment. For a DC motor the optimal length of the wires depends on the voltage and current that runs through the motor wires, and the voltage and current depend on the resistance of the wires, which is directly related to the length of the wires. In order to assure that such a coupled system is optimized, the design and control optimizations must be combined in some manner.

Ideally, the combined optimization problem should appear as in Fig. 3. A system objective is optimized to find appropriate values for the variables \mathbf{d} and \mathbf{p} with system parameters \mathbf{a} and \mathbf{u} . The design and control must be solved simultaneously in agreement with the internal coupling quantities \mathbf{b} and \mathbf{v} that vary to allow the matching of \mathbf{b} with \mathbf{B} and \mathbf{v} with \mathbf{V} . The difficulty with this setup is that this agreement of the coupling quantities requires the constraints to be solved as a set of simultaneous, algebraic, differential equations, including both equalities and inequalities. Solving this set of equations is very challenging in itself. Furthermore, the entire set of equations may not be readily examined since differential equations for the dynamic system are often represented by complex simulations rather than explicit equations. Combined problem solution techniques must each address the coupling parameter issue for models that have both \mathbf{b} and \mathbf{v} types of parameters.

Selection of an objective for optimization of the combined problem is also an issue. For a DC motor, perhaps the system goal is to make the most profit selling motors. A design objective of minimizing the weight may be equivalent to minimizing the cost of the motor. Customers may be more willing to pay for the motor if it has a minimum response error and uses a minimum amount of electricity, as posed by a control objective. Which goal will make the most profits: reducing costs or increasing sales? The answer must certainly depend on the relative importance of the two goals in the customers’ mind; this suggests some form of a weighted objective, for example, linearly combining the design and control objectives. A Pareto solution will be typically generated. Of course, sales of products in real markets may not even be directly related to technical criteria, but could be driven by aesthetics or life style perception. Assuming that quantifiable objectives can be found, the combined design and control problem can be addressed as a multicriteria optimization problem. Studying such objective formulations in depth is beyond the scope of the present article; we will assume that a simple linearly weighted objective leading to Pareto solutions will suffice.

minimize (system objective)

Variables: \mathbf{d}, \mathbf{p}

Parameters: \mathbf{a}, \mathbf{u}

Internal Variables: \mathbf{b}, \mathbf{v}

Subject to:

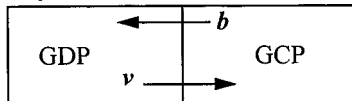

Fig. 3 Desired combined problem setup

The next section presents a DC motor model that exhibits all of the qualities described above.

3 DC Motor Model

In a DC motor, mechanical design determines the rotor dimensions and winding characteristics; control design determines the input voltage or current (depending on the type of motor) needed to control the rotational response of the rotor. The particular example motor needs to operate at half speed under a specified load and with a desired speed. Goals of the system are to minimize the weight of the motor, the speed response error for the test, and the voltage required to drive the motor during a test schedule. See Table 2 for nomenclature.

3.1 Motor Design Problem. The design problem examines the static characteristics of the motor, such as the number of turns on the field coils and the full load power rating of the motor. The design objective is to minimize the motor’s weight subject to constraints on the configuration (windings, magnetic fields) and constraints on service requirements (speed, power). The design equations for creating the DC motor model given below in Eq. (1) were developed using the text by Hamdi [7].

$$\text{minimize}_{D,L,Lwa,Lwf,ds} W = \rho_{cu}(A_{wa}L_{wa} + A_{wf}L_{wf}) + \rho_{fe}L\pi(D + d_s)^2$$

subject to:

Table 2 Nomenclature for DC motor model

A_{wa}	A_{wf}	cross sectional area of wires - assumed constant
ac		specific electrical loading - function of variables
B		friction coefficient - assumed constant
B_g		maximum flux density - function of variables
b_{fc}		depth of field coil - assumed constant
D		rotor diameter - design variable
d_s		depth of slots - design variable
J_{cf}		copper space factor - a constant
h_f		field winding height - function of variables
I_f		field current - function of variables
$i(t)$		current - state variable
J		performance index - control objective
J_a		rotor inertia - coupling, to control
K_m		motor constant - coupling, to control
L		rotor axial length - design variable
L_a		inductance of armature windings - coupling, to control
L_{mf}		mean turn length of field coil - function of variables
L_{wa}		length of armature wire - design variable
L_{wf}		length of field wire - design variable
K_d		derivative controller gain - control variable
K_i		integral controller gain - control variables
K_p		proportional controller gain - control variable
n		rotational speed - coupling, to design
p		number of poles - assumed constant
P_{min}		minimum required power - coupling, to design
Q, r		regulator weights
R		resistance of armature - coupling, to control
S		number of slots or teeth on rotor - assumed constant
T_{min}		minimum required torque - coupling, to design
V		design voltage- coupling, to design
W		weight of motor - design objective
$z(t)$		voltage - controller signal
$\omega(t)$		angular velocity of rotor - state variable
ρ		resistivity - assumed constant
ρ_{cu}	ρ_{fe}	densities of copper and iron -a constant
$\tau_L(t)$		load torque - function with known profile
ψ		pole arc to pole pitch ratio -assumed constant

$$\begin{aligned}
h_1 &= ac - \frac{2b_3L_{wa}}{\pi\eta ab_1\left(2L + \frac{2.3\pi D}{p} + 5d_s\right)D} \\
h_2 &= I_f - \frac{A_{wf}^2 b_1}{h_f L_{mf} b_{fc} f_{cf} p \rho} \quad h_3 = B_g - \text{func}(ac) \\
h_4 &= L_{mf} - \left(L + 2b_{fc} + \frac{\psi}{L}\right) \quad h_5 = h_f - \frac{0.76\psi}{L} \\
g_1 &= \frac{\pi D}{p} - 0.38 \quad g_2 = \frac{2DB_g}{(D-2d_s)} - 1.8 \\
g_3 &= \frac{\pi D}{b_2} - 25 \quad g_4 = 8 - \frac{\pi D}{b_2} \\
g_5 &= \frac{Lp}{\pi D} - 0.9 \quad g_6 = 0.6 - \frac{Lp}{\pi D} \\
g_7 &= \frac{2D}{(D-2d_s)} - 3.5 \quad g_8 = 2.5 - \frac{2D}{(D-2d_s)} \\
g_9 &= B_g - 0.8 \quad g_{10} = 0.3 - B_g \\
g_{11} &= d_s - \frac{2\pi(D-2d_s)}{S} \quad g_{12} = d_s - 0.5D \\
g_{13} &= ac - 20 \quad g_{14} = 6 - ac \\
g_{15} &= b_3 - \pi^2 \psi B_g ac D^2 L b_2 \\
g_{16} &= b_4 - \frac{\pi}{2} \psi B_g ac D^2 L \\
g_{17} &= \frac{1.2L_{wa}A_{wa}}{2L + 2.3\frac{\pi D}{p} + 5d_s} - \pi\left(\left(\frac{D}{2}\right)^2 - \left(\frac{D}{2} - d_s\right)^2\right) \\
g_{18} &= 500 - \frac{I_f^2 L_{wf} \rho}{A_{wf}(L_{mf} + b_{fc})h_f} \\
g_{19} &= \frac{I_f^2 L_{wf} \rho}{A_{wf}(L_{mf} + b_{fc})h_f} - 750
\end{aligned}$$

For the control problem:

$$\begin{aligned}
V_1 &= R_a = \frac{\rho L_{wa}}{4A_{wa}} \\
V_2 &= K_m = K_m(D, L, L_{wa}, L_{wf}, b_1, p, A_{wa}, A_{wf}) \\
V_3 &= L_a = \frac{\pi\psi\mu_0 L_{wa}^2 DL}{0.025\pi D\left(2L + \frac{2.3\pi D}{p} + 5d_s\right)^2} \\
V_4 &= J_a = 0.5\pi\rho_{fe}L\left(\frac{D}{2} - d_s\right)^2 + 0.5\rho_{cu}L_{wa}A_{wa}\left(\left(\frac{D}{2}\right)^2 + \left(\frac{D}{2} - d_s\right)^2\right)
\end{aligned}$$

Using the variable and parameter definitions of Section 2, the design variables are $\mathbf{d} = [D, L, L_{wa}, L_{wf}, d_s]^T$ and the parameters are $\mathbf{b} = [n, V, P_{\min}, T_{\min}]^T$ and $\mathbf{a} = [\rho_{cu}, \rho_{fe}, \psi, p, S]^T$. Parameters for the control problem are computed for the vector $\mathbf{v} = [V_1, V_2, V_3, V_4]^T$. Figure 4 offers a pictorial representation of the problem structure.

3.2 Motor Control Problem. The DC motor control problem may take any of several forms, depending upon how the

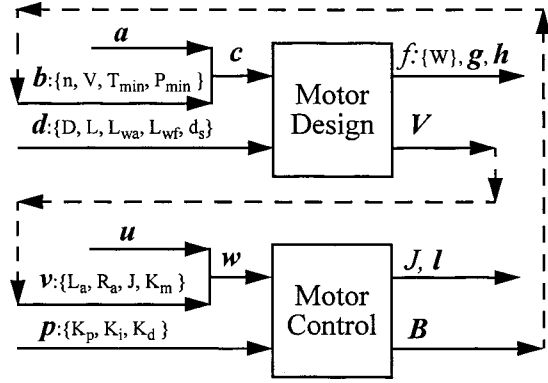

Fig. 4 Motor design and control problem

motor is wound and where the controller is applied. For this problem, an armature-controlled motor will be examined with a proportional plus integral plus derivative (PID) controller configuration, which requires the choice of three control gains.

- (1) As shown in the lower half of Fig. 4, the controller has two inputs, control gains \mathbf{p} and parameters \mathbf{w} , and three outputs, performance index J , control constraints \mathbf{l} and parameters for the design problem \mathbf{B} . The model is as follows:

$$\text{minimize}_{K_p, K_i, K_d} J = \int_0^{t_f} \omega_{\text{err}}^T \mathbf{Q} \omega_{\text{err}} dt + V_{\max}$$

subject to:

$$\begin{aligned}
\begin{bmatrix} i \\ \omega \end{bmatrix} &= \begin{bmatrix} -v_1 & -v_2 \\ v_3 & v_3 \\ v_2 & B \\ v_4 & v_4 \end{bmatrix} \begin{bmatrix} i \\ \omega \end{bmatrix} + \begin{bmatrix} 1 \\ v_3 \\ 0 \end{bmatrix} \mathbf{z} + \begin{bmatrix} 0 \\ -1 \\ v_4 \end{bmatrix} \tau_L \\
\mathbf{y} &= [0 \ 1] \begin{bmatrix} i \\ \omega \end{bmatrix}
\end{aligned}$$

$$\frac{z(s)}{\mathbf{E}(s)} = K_p + \frac{K_I}{s} + K_D s \quad \mathbf{E}(s) = \mathbf{y}(s) - \mathbf{y}_d(s)$$

$$l_1 = -K_p \quad l_2 = -K_i \quad l_3 = -K_d \quad (2)$$

$$B_1 = V_{\max} = \max(\mathbf{z}) \quad B_2 = n = \max(\omega)$$

$$B_3 = P_{\min} = \max(\mathbf{z}i)$$

$$B_4 = T_{\min} = \max(K_m i - \tau_L)$$

Using the variable and parameter definitions of Section 2, we have $\mathbf{x}(t) = [\omega, i]^T$, $\mathbf{p} = [K_p, K_i, K_d]$, $\mathbf{v} = [L_f, R, K, J]^T$, and $\mathbf{u} = [B, Q, r, \tau_L]^T$, with the voltage applied to motor as the control signal $\mathbf{z}(t)$.

The PID controller is perhaps the most common control strategy used in industry. The optimal gain problem for the motor with a PID controller configuration will be solved numerically. Other control strategies such as the linear quadratic regulator (LQR) could permit direct analytical solution of an unconstrained optimal control problem. However, in some of the solution strategies, optimizing the combined system may not demand an optimal controller, so replacing the optimal control problem with the analytical equation for control optimality may not be desirable.

3.3 Motor System Model. For the complete system problem shown in Fig. 4, special attention should be paid to the flow of the parameters \mathbf{b} and \mathbf{v} . In traditional design and control of a motor, one set of parameters, typically \mathbf{b} , is specified in the problem statement—for example, a desired horsepower and voltage motor. For an optimal system, however, one might expect that the

size for which the motor system is designed should identically match the size that the controlled system requires; extra size has no advantage. Since the controlled system depends upon the motor's characteristic parameters v , and the designed system depends on the motor's controlled parameters b , the flow of parameters forms a loop in the optimal system design. Each design scenario must address the numerical solution of the loop formed by these parameters.

The design objective of minimizing the weight is assumed to be proportional to the cost of the motor. It is also assumed that the value of the motors is proportionally higher if it has a minimum response error and uses a minimum amount of electricity, as posed in the control objective. In the linearly weighted system objective the weights are considered initially to be equal. The two objectives, the motor weight and the control performance index, have different orders of magnitude, and they are scaled by multiplying the design objective by ten. Selecting different weights will be explored further below.

4 Solution Strategies

This section addresses strategies that can be used to solve optimization formulations for the separate and combined design and control problems. The strategies presented are divided into two categories: sequential and concurrent strategies.

In *sequential strategies*, including "single pass" and "iterative" strategies, two separate optimizations, one for the design problem and one for the gain problem, are performed in an unrelated manner. The *single pass strategy* follows the traditional plan: an optimal design is found, followed by optimal controller gains, and the system is checked for acceptability. The single pass solution is dependent on initial guesses for one set of coupling parameters—the parameters of one problem that are dependent on the solution to the other problem. The *iterative strategy* attempts to remove this dependency by repeatedly finding an optimal design and an optimal controller until the coupling parameters match. The sequential strategies present a difficulty in system optimization: while one can prove that the design is optimum and the controller is optimum, there is no straightforward mathematical way to prove that the combined system is optimum.

The *concurrent strategies*, including "decoupled system", "all at once" and "bilevel" strategies, enable consideration of optimality conditions for the entire system. In the *decoupled system strategy*, a direct extrapolation of the single pass strategy, one set of coupling parameters is fixed and optimization is performed on the combined system. As in the single pass technique, the result also depends on the initial guesses for the coupling parameters. The *all at once strategy* removes that dependency. The coupling parameters are treated as variables and the output parameters resulting from a design/control sequence must match the corresponding input variables. This method, however, tends to be the most challenging to solve computationally. The *bilevel strategy*, developed for structural applications, treats the optimal gain selection as a subproblem to the system optimization problem. If the optimal gain selection problem is formulated as a linear quadratic regulator (LQR), an analytical solution may be found. If the problem is not an LQR, other control techniques may be applied to find an optimal controller. In either case the combined problem becomes significantly more tractable. In the motor study we use this strategy with a PID controller.

In general, the concurrent optimization strategies are more difficult to solve than the sequential strategies. However, the advantage of being able to know whether or not a solution is a mathematical optimum of the system may be worth the extra effort. The remainder of this section examines in more detail each of the five design scenarios applied to the DC motor study.

4.1 Single Pass Strategy. Design and controller are optimized separately, taking full advantage of the analysis techniques in each discipline. The separation is achieved by fixing a set of initial coupling parameters, either b or v , and then sequentially

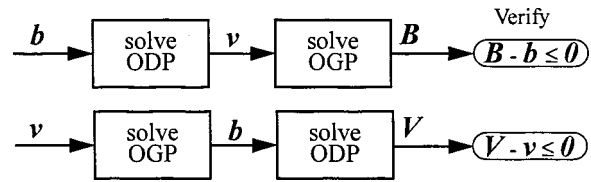

Fig. 5 Single pass strategy

finding an optimal design and corresponding optimal gains, Fig. 5. The coupling parameters, which are inputs to the design and outputs from the control or vice versa, are examined for acceptability. As long as the resulting B or V indicate that the system requirements were met (for example, the designed power is larger than the amount of power to which the controlled motor is subjected), the method terminates and the solution could be deemed "optimal" from both the design and control points of view. From a system level point of view, this "optimal" solution could be wrong whenever non-zero differences exist between b and B or v and V . Further, the design-first-then-control and the control-first-then-design solutions do not necessarily match; in fact, one would expect them not to match unless the initial parameter values were perfectly chosen. Thus, the system analyst could have two different "optimal" solutions without being able to express further preference.

4.2 Iterative Strategy. The iterative strategy takes advantage of the separate design and control analysis techniques, while addressing two of the drawbacks in the single pass strategy: the dependence of the solution on the initial guess for the coupling parameters and the probable difference of the design-first-then-control and the control-first-then-design solutions. This is achieved by adding a feedback loop to the single pass strategy, Fig. 6. The system is repeatedly designed and controlled until the coupling parameters, b and B or v and V , are matched within some tolerance or a preset number of iterations has been performed. The "optimal" iterative solution must have optimal solutions for both the design and control problems, and the parameters must match. For example, the power for which the motor is optimally designed must match the power used by the optimally controlled motor. The immediate consequence of the iterative process is that both the design-first-then-control and the control-first-then-design sequences should give the same optimum (for a unimodal problem) with a sufficiently tight termination criterion and sufficiently many iterations. At the system level, these solutions could more plausibly be called "optimal" than the single pass solutions, although there is no mathematical proof for the argument. To achieve an optimum mathematically, conclusions must be drawn based on the system goals.

4.3 Decoupled System Strategy. This combined design and control strategy allows the sequential use of the design and control problems, while the entire system is optimized. As in the single pass strategy, this strategy requires fixing the input

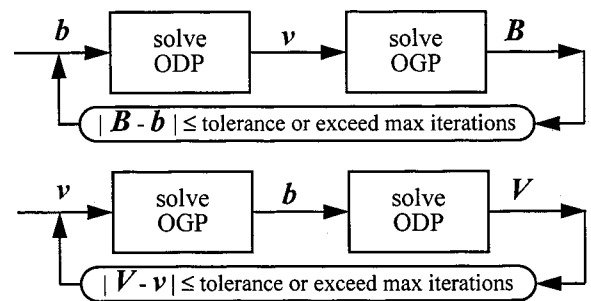

Fig. 6 Iterative strategy

parameters, b or v , and constraining the resulting B or V to be acceptable, as shown in Fig. 7. Acceptability is identical to that from the single pass strategy, in that the designed-for condition, b or v , needs to be at least as large as the level, B or V , which results. For example, the power for which the motor is designed needs to be larger than the power used by the controlled motor for satisfactory operation. Again, there is an undesirable parametric dependence on the input b or v , but judicious selection of those parameters can lead to an overall improvement of the solution to the combined problem as compared to the sequential formulation. Since this optimization is performed on a system representation, a mathematical optimum can be declared, yet the dependence of the solution on one of the sets of parameters may make this method somewhat undesirable.

4.4 All At Once Strategy. Perhaps the best method for achieving the system optimum involves a problem combination with the input parameters as variables—an all at once (AAO) methodology. One set of coupling parameters, either b or v , become variables and acceptability constraints are imposed on the corresponding output parameters, B or V , after a design and control solution cycle, Fig. 8. There is a temptation to require that the coupling parameters identically match. However, such a set of equality constraints puts a stricter requirement on the optimum, reduces the feasible space, and potentially gives a worse solution. In all likelihood, some of these constraints will be active, but the optimization algorithm should determine this. With this formulation, the optimal solution is mathematically provable at the system level. The drawbacks of both the sequential strategies and the decoupled system strategy are removed, but the problem is larger and the method is more computationally demanding. If solution is possible, the AAO strategy should be preferred for solving the system optimization problem.

4.5 Bilevel Strategy. Here, the optimal gain problem is treated as a subproblem of the optimal system problem, Fig. 9 [1,2,8,9]. This strategy finds the minimum combined objective for the system, assuming that the system optimum occurs when the gain problem is minimized. The main advantage is that techniques for solving the optimal gain problem may be directly applied. In structural applications a common controller configuration is the linear quadratic regulator (LQR) whose optimal gain problem has an analytical solution—a mathematical expression that solves the problem and eliminates the need for numerically intensive iterations. Outside the structures field, the most prevalent controller configuration is the PID controller. Though the optimal PID gain problem does not typically have a direct analytical solution, it may be asserted that using an alternate controller configuration such as a PID controller will not change the form of the system optimization strategy. In the case study here, the motor is controlled using the PID control strategy. Future work is expected to confirm that the system optimization solution strategies are not affected by such a change in controller configuration.

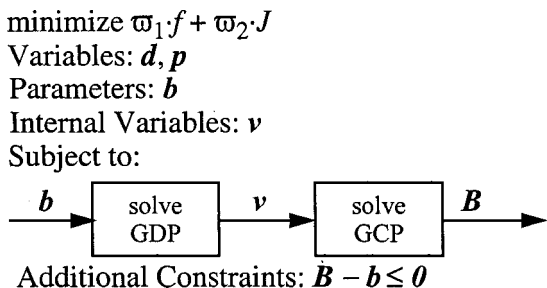

Fig. 7 Decoupled system strategy (b fixed)

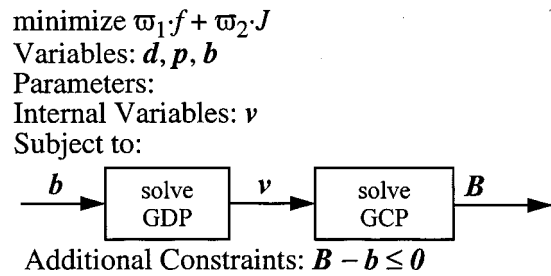

Fig. 8 All at once strategy (b variable)

5 DC Motor Design

Optimization of the DC motor was performed using a sequential quadratic programming (SQP) algorithm. Since SQP finds local optima, a multi-starting point technique was employed in the search. These starting points included the values that result from the all at once strategy. Even then, the other methods move away from the starting values of the system optimum. Three causes of this phenomenon are that (1) the fixed parameters were not held at their system optimal values, (2) the AAO solution is infeasible due to the way the alternative strategy assembles the constraints, or (3) the coupling parameters change from their system optimal values due to the sequence of solving the design and then the control problem. Though the interpretation of these events is not presented in this work, subsequent work has confirmed that these causes result from the formulations of each strategy and not from numerical difficulties [10,11].

In Table 3 the results are presented for the different design scenarios as applied to the DC motor. Divided cells in the table represent the values for b or v (top) and B or V (bottom). In the remainder of this section we will briefly discuss these results and their significance.

5.1 Single Pass Strategy. From Table 3, the traditional single pass strategies are the worst, with both high design weights and high performance indices. In addition to having the worst objective, the dependence of the method on the input parameters, b and v , make it undesirable. Considering the other solutions in the table, picking the best of the single pass solutions does not necessarily qualify the single pass strategy as a reasonable approach to obtain the optimal system level solution.

5.2 Iterative Strategy. The iterative design-first strategy is an improvement over the single pass design-first strategy while the iterative control-first strategy is not. This demonstrates the importance of the choice of the next iterate in this method. Using a naïve algorithm, such as replacing the old coupling parameter value with the new iterate, a poor initial solution may lead to an even worse solution. However, a more judicious iterate selection process indicates that the iterative solutions can improve the single pass ones and require no new theories or problem formulations. With a good iterate selection process and enough iterations, the results become similar regardless of the order of the

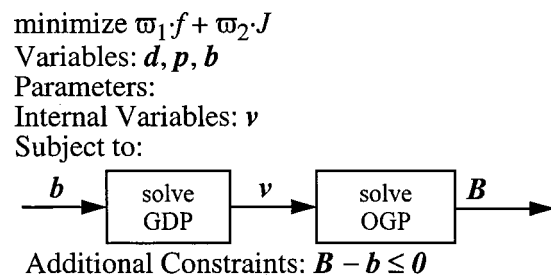

Fig. 9 Bilevel strategy

Table 3 Motor optimization results

Variable	Motor Symbol	Variable Description	Single Pass		Iterative		Concurrent		
			Design First	Control First	Design First	Control First	Decoupled System	All At Once	Bilevel
Labels for figures→			SP-DF	SP-CF	I-DF	I-CF	C-DS	C-AAO	C-BL
$\varpi_1 \cdot f + \varpi_2 \cdot J$		combined objective $\varpi_1=\varpi_2=0.5$	74.03	109.17	72.99	116.77	70.30	44.81	48.28
$f/10$	W	weight (kg)	7.90	14.42	8.89	15.19	8.39	6.23	6.21
J	J	performance Index	69.04	74.15	57.12	81.61	56.69	27.28	34.50
d_1	D	diameter (cm)	6.89	10.41	6.71	10.80	6.89	6.56	6.72
d_2	L	rotor length (cm)	9.74	9.81	9.49	10.18	9.74	9.28	9.50
d_3	L_{wa}	arm. wire length (m)	89.53	132.26	91.80	114.78	89.53	16.86	23.69
d_4	L_{wf}	field wire length (m)	220.0	437.8	523.34	413.4	330.0	299.7	193.9
d_5	d_s	slot depth (cm)	1.08	1.95	1.05	2.02	1.08	1.02	1.05
v_1	L_a	inductance (cH)	10.57	13.00†	11.41	12.57	10.57	0.39	0.76
V_1			10.57	12.83	11.41	12.83	10.57	0.39	0.76
v_2	R_a	resistance (c Ω)	20.07	22.00†	20.58	22.12	20.07	3.78	5.31
V_2			20.07	29.65	20.58	12.83	20.07	3.78	5.31
v_3	J_a	inertia (kg m ²)	0.0029	0.003†	0.0027	0.0097	0.0029	0.0014	0.0017
V_3			0.0029	0.0098	0.0027	0.0106	0.0029	0.0014	0.0017
v_4	K_m	motor constant	0.19	0.20†	0.30	0.20	0.28	0.05	0.06
V_4			0.19	5.71	0.30	0.250	0.28	0.05	0.06
p_1	K_p	proportional gain	1.24	1.33	0.99	1.44	0.99	0.53	0.61
p_2	K_i	integral gain	6.89	6.91	7.81	4.67	7.56	6.53	8.26
p_3	K_d	derivative gain	0.00	0.00	0.00	0.00	0.00	0.00	0.00
b_1	n	rot. speed (rad/s)	45.00†	24.47	37.93	23.58	45.00†	121.28	118.45
B_1			24.69	24.47	24.14	23.58	23.99	22.52	24.06
b_2	V_t	voltage (V)	44.00†	34.88	26.77	36.01	44.00†	40.07	53.76
B_2			28.20	34.88	26.61	36.01	26.51	13.53	16.44
b_3	T_{min}	torque (Nm)	6.00†	5.63	5.55	5.51	6.00†	5.18	5.54
B_3			5.68	5.63	5.55	5.51	5.18	5.18	5.54
b_4	P_{min}	power (kW)	0.90†	0.57	0.51	0.67	0.90†	3.95	3.94
B_4			0.64	0.57	0.32	0.67	0.33	0.97	1.06

optimization (though one could foresee differences if the problem had multiple optima). There is no dependence on guessed parameter values. A difficulty of this strategy is that there is no information about the system's optimality conditions: mathematically, one cannot prove or disprove that the result is an optimum. Also, without system level sensitivity (Lagrange multipliers), there is no way of knowing how the optimum will change when a constraint is perturbed.

5.3 Concurrent Strategies. The concurrent strategies produce better results than the sequential strategies. The decoupled system strategy provides a better objective value than the sequential strategies. Some of the coupling parameters are satisfied at the same values as the design-first single pass solution. However, the problem of the dependence on the input parameters is still present. The bilevel strategy has the second best "optimal" solution. Further study of this method as applied to the motor indicates that the method may not allow the full exploration of the feasible space, due to the requirement that the controller be optimal at each feasible point in the system level optimization. Examination of this phenomenon requires further research. Overall, the best optimization

result comes from using the AAO strategy. The solution meets the optimality conditions, guaranteeing that it is indeed a local optimum.

5.4 Motor Sizing. As shown in Table 3, the design scenario find an outwardly similar motor whose diameter and length are close. The major difference occurs in the windings of the motor. The better solutions have significantly smaller armature windings, even sacrificing an increase in the field windings. This reduces the weight of the motor and also reduces the control coupling parameters, the resistance, inductance and inertia of the armature. The reduced coupling parameters allow a faster response in the controlled motor. The integral gains for the controllers are also similar, but the proportional gains are smaller in the two better solutions.

5.5 Constraints. Table 4 presents a comparison of the active constraints at the "optimal" solutions for each strategy. In all solutions, the design torque constraint, g_{16} , is active. Constraint g_{18} , the lower bound on the permissible heat loss per unit area of the winding surface, is active in all sequential strategies while the

Table 4 Active constraints

Constraint		SP-DF	SP-CF	I-DF	I-CF	C-DS	C-AAO	C-BL
#	Description							
g_1	UB pole pitch							
g_2	UB magn. saturation	■		■		■	■	■
g_3	UB rotor peripheral speed						■	
g_4	LB rotor peripheral speed		■	■	■			
g_5	UB length to pole pitch ratio	■				■	■	
g_6	LB length to pole pitch ratio		■		■			
g_7	UB slot/diameter sizing							
g_8	LB slot/diameter sizing							
g_9	UB maximum flux density							
g_{10}	LB maximum flux density							
g_{11}	tooth width to slot depth ratio		■		■			
g_{12}	geom. slot depth limit							
g_{13}	UB specific electrical loading	■		■		■	■	■
g_{14}	LB specific electrical loading							
g_{15}	motor design power						■	
g_{16}	motor design torque	■	■	■	■	■	■	■
g_{17}	geom packing limit							
g_{18}	LB allowable heat loss per unit of surface area	■	■	■	■			
g_{19}	UB allowable heat loss per unit of surface area					■		■
l_1	positivity of gain K_p							
l_2	positivity of gain K_i							
l_3	positivity of gain K_d	■	■	■	■			■
b_1	i/o voltage coupling parameter							
b_2	i/o speed coupling parameter							
b_3	i/o power coupling parameter							
b_4	i/o torque coupling parameter						■	■

upper bound g_{19} is active in the decoupled system and bilevel strategies. Interestingly, neither is active for the all at once strategy that provides the best solution. The sequential control-first strategies find the lower bound of the length to pole pitch ratio g_6 active while the other strategies, except for the iterative design-first strategy, have the upper bound g_5 active. The limit on the

tooth width to slot depth ratio g_{11} is active only for the control-first strategies. The design-first and the concurrent strategies find the magnetic saturation g_2 and the bound on the specific electrical loading g_{13} to be active. The iterative and the single pass design-first strategies have the lower bound on the armature's peripheral speed g_4 active, while the decoupled system strategy identifies the upper bound as active. The differences between the sequential and concurrent strategies, especially where the bounds on a value switch from lower to upper, indicate a strong need to examine overall system optimality conditions when using the traditional sequential strategies.

5.6 Motor Responses. The response and input signal are of particular interest in the control of a system. Figure 10 shows the speed responses, input voltages, and power responses for the critical first second of the simulation at the optimal solution. The best controller uses the least voltage and has the fastest response with very little overshoot. The bilevel strategy also has a fast response and uses a small voltage, but with high overshoot and power requirements. In contrast the bilevel strategy has the largest integral gain, while the AAO strategy has one of the smallest. The sequential strategies have slower controlled responses, more overshoot, higher voltages and less power. The decoupled system strategy generally falls between the other concurrent strategies and the sequential strategies.

5.7 Pareto Solutions. The concurrent strategies that provide better solutions create a new difficulty: the definition of the combined objective. In this study a weighted sum objective was used. Table 3 presented the results for equally weighted objectives. Further examination of the all at once strategy leads to the development of a Pareto set that indicates the effect of the weights on the optimal solution. By varying ϖ_1 and letting $\varpi_2 = 1 - \varpi_1$, the Pareto curve in Fig. 11 is created. Also included in the figure are the locations of the solutions from the other strategies. Any hope as to whether the other strategies were actually finding an optimum that could be achieved with different weights is not justified. Some progression from the single pass to the iterative strategies is evident. Although the control-first strategy moves further from the Pareto curve, the design-first strategy moves toward the curve. It is not expected that the trend will eventually reach the Pareto curve. As previously discussed, the iterative strategies' attempt to achieve matching coupling parameters actually places a stricter requirement on the solution than carefully chosen inequalities.

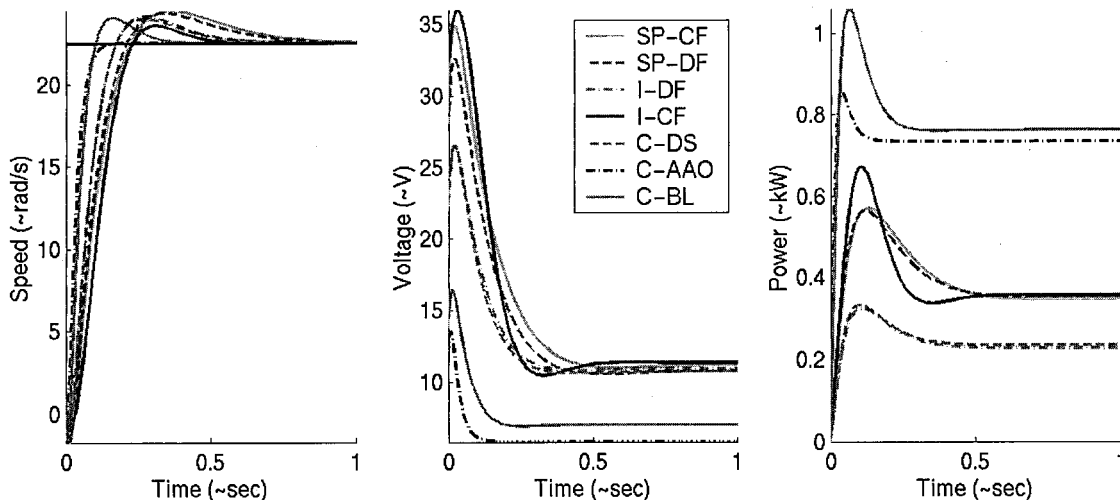

Fig. 10 Responses (abbreviations as in Table 3)

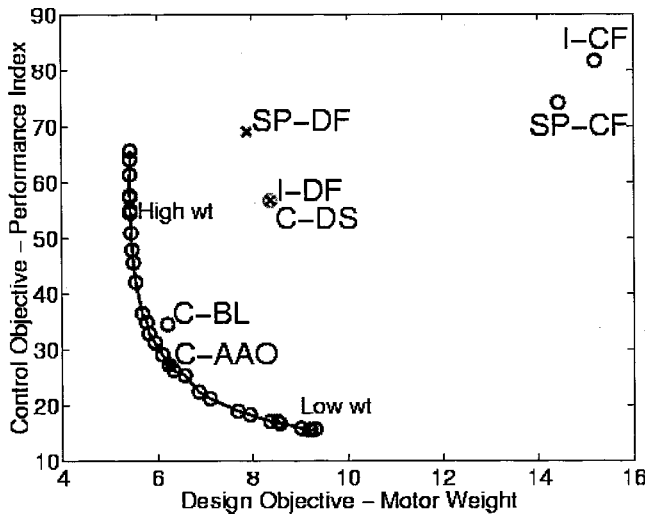

Fig. 11 Pareto solutions (abbreviations as in Table 3)

6 Conclusion

The DC motor model provided some interesting insight into the optimization of fully coupled design and control systems. The typical separation of optimal design and optimal control does not lead to an optimal system. Rather, the artifact design and control analysts need to integrate their modeling tasks to explore system-level optima. This presents both intellectual and mathematical challenges.

Design and control analysts generally do not think in the same terms. However, the mathematical rigor of optimality conditions is necessary for combined design and control systems, and further investigation of new types of combined objectives is needed. Optimization methods may be called into question as the size of the combined system model increases. Even if both the design and control models can be considered separately as small-scale solvable systems, the combined system may cross the line into large scale system optimization, where there are too many variables, too

many constraints or too expensive function evaluations for the typical optimization routines. However, as these issues are being addressed, improved electromechanical systems are sure to result.

Acknowledgments

This research was partially supported by the U.S. Army Automotive Research Center for Modeling and Simulation of Ground Vehicles under contract number DAAE07-98-R-L008. This support is gratefully acknowledged. The authors also wish to thank Professor A. G. Ulsoy for his helpful suggestions.

References

- [1] Bendsøe, M. P., Olhoff, N., and Taylor, J. E., 1987, "On the Design of Structure and Controls for Optimal Performance of Actively Controlled Flexible Structures," *Mech. Struct. Mach.*, **15**(3), pp. 265–295.
- [2] Hale, A. L., Lisowski, R. J., and Dahl, W. E., 1985, "Optimal Simultaneous Structural and Control Design of Maneuvering Flexible Spacecraft," *Journal of Guidance, Control, and Dynamics*, **8-1**, pp. 86–93.
- [3] Isermann, R., 1996, "Modeling and Design Methodology for Mechatronic Systems," *IEEE/ASME Trans. Mechatron.*, **1**(1), pp. 16–28.
- [4] Skelton, R. E., 1985, "On the Structure of Modeling Errors and Inseparability of the Modeling and Control Problems," *IFAC Model Error Concepts & Compensations*, New York, John Wiley & Sons.
- [5] Youcef-Toumi, K., 1996, "Modeling, Design and Control Integration: A Necessary Step in Mechatronics," *IEEE/ASME Trans. Mechatron.*, **1**(1), pp. 29–38.
- [6] Brusher, G. A., Kabamba, P. T., and Ulsoy, A. G., 1997, "Coupling Between the Modeling and Controller Design Problems, Part II: Design," *ASME J. Dyn. Syst., Meas., Control*, **119**, pp. 278–283.
- [7] Hamdi, E. S., 1994, *Design of Small Electrical Machines*, New York, John Wiley & Sons.
- [8] Khot, N. S., and Abhyankar, N. S., 1993, "Integrated Optimum Structural and Control Design," in *Structural Optimization: Status and Promise*, **150**, Progress in Astronautics and Aeronautics (M. P. Kamat, Ed.), Washington, D.C.: American Institute of Aeronautics and Astronautics, pp. 743–767.
- [9] Park, J.-H., and Asada, H., 1994, "Concurrent Design Optimization of Mechanical Structure and Control for High Speed Robots," *ASME J. Dyn. Syst., Meas., Control*, **116**, pp. 344–356.
- [10] Reyer, J. A., and Papalambros, P. Y., 2000, "An Investigation into Modeling and Solution Strategies for Optimal Design and Control," *ASME Design Engineering Technical Conferences*, Paper DAC-14253, Las Vegas, Nevada, September 10–13.
- [11] Reyer, J. A., Fathy, H., Papalambros, P. Y., and Ulsoy, A. G., 2001, "Comparison of Combined Embodiment Design and Control Optimization Strategies using Optimality Conditions," *ASME Design Engineering Technical Conferences*, Paper DAC-21119, Pittsburgh, Pennsylvania, September 9–12.